

ARCA-SWISS

**a tradition in
photographic
technology**

Innovative designs mark the progress of this Swiss company.

ARCA-SWISS started producing professional cameras in the early fifties.

The new Swiss **All-Round-C**Ameras, ARCA-SWISS, rapidly gained an excellent reputation based on their precision and handling in practical situations. The first large-format reflex cameras, 6x9cm and 4x5" appeared in 1960 and were the rage of Photokina. Panoramic cameras and riflescopes followed soon thereafter. Many companies were awarded ARCA-SWISS subcontracts given the large potential for innovation. Philippe Vogt took the company over in 1984. A new era characterised by an extensive redesign of the entire line commenced.

A myriad of technologically advanced products, such as the first electronic professional camera, the monoball® B ballhead, SIM light metering, digital backs and the successful M-Line and F-Line system's concept were created by his team.

Modular design, extensive system component interchangeability, and the superb engineering and construction of the cameras are held in high esteem by professionals the world over. ARCA-SWISS clients are the world's most demanding photographers and the leading schools of photography and design, as well as those of architecture, science and technology.



No limits: the ARCA-SWISS camera system, with its standardised - and therefore interchangeable - components, gives the photographer all the options needed to match the equipment to any imaginable assignment.



ARCA-SWISS F -metric 6x9

ARCA-SWISS cameras grow and change to match the photographer's knowledge, experience and preferences. The camera does not dictate terms; rather, the photographer alone decides which components are required. Even in this age of electronic image capturing, advanced large-format cameras with their range of movement are the only solution to many common technique problems. ARCA-SWISS cameras offer perfectly designed, ergonomic controls to optimally adjust perspective and planes-of-focus quickly and precisely. The result: arresting images showing perfect perspective, a well-chosen plane of focus, clear details and rich colour and saturation.

ARCA-SWISS F-Line and M-line cameras are market leaders as the most versatile image capturing devices available. Both camera lines consist of functionally optimized precision instruments. Their ergonomically inspired elegance is not only optically pleasing, but also offers the highest degree of ease-of-use. The step from commercial 6x7cm medium format to the large sheet-film formats of 5x7" or 8x10" is child's play: from the lightweight and universal F-Line, the compact F-Line C with its collapsible monorail, to the versatile and rugged M-Line - all yaw-free and modular.



ARCA-SWISS F -metric 4x5"



ARCA-SWISS M -monolith 6x9 medium format camera with binocular viewer



ARCA-SWISS F -classic C 6x9 /8x10"



Fast format changes

Anyone who owns an ARCA-SWISS M-Line or F-Line camera is never limited by format sizes. Format changes happen in a flash: simply switch conversion sets. No additional accessories are required to move from 6x7cm all the way up to 8x10". The 4x5" frame is a component common to a variety of setups. When mounted on the rear carrier, it holds the groundglass and film holders; mounted on the front carrier, it carries lens boards for various film formats; it can even support the bellows in long extensions.



Completely interchangeable

ARCA-SWISS format frames can be swapped from front standard to rear standard. This design offers the most flexible system and format option package available.

The format frames

The **F-classic** format frames have an integrated manual rise and fall mechanism which is controlled via lock-knobs.

F-metric cameras offer self-locking geared rise and fall movements.

M-monolith format frames do not have integrated rise and fall controls as this movement is performed by the function carrier.

The orientation of the swing axes is identical on all cameras.

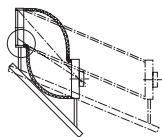

Unobstructed optical path

Thanks to generous dimensions, neither the bellows nor the format frames on ARCA-SWISS cameras interfere with the light passing through to the film.

Vignetting is often not caused by the lens but rather because the bellows are too small.

Not so with ARCA SWISS cameras: large bellows diagonals mean there is no interference with the image - both to eliminate the possibility of vignetting and also to produce higher image contrasts.

Practical image adjustment controls

ARCA-SWISS cameras offer ergonomically designed and matched controls for the movements that determine sharpness and perspective.

Separating the shift and swing functions makes it possible to swing and focus simultaneously in critical situations.

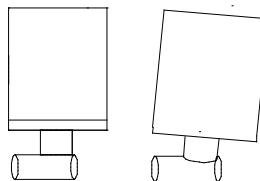

Triaxial yaw-free is the new standard for yaw freedom set by the ARCA-SWISS M-monolith in 1987. Up until that point, cameras only offered limited yaw freedom. ARCA-SWISS cameras outfitted with the **orbix®** device are triaxial yaw-free.

Definition of orbix® movements: the optics move at the centre of a circle which is perpendicular to the base of the frame and is located above the vertical movement axis.

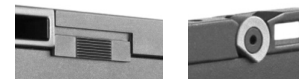
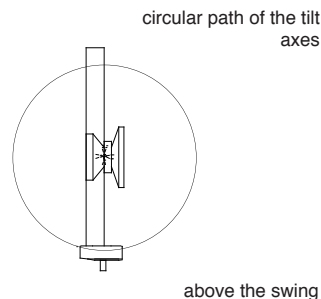

Self-lock

One hand is all you need to mount bellows units, film holder adapters, digital backs and lens boards. The units lock themselves in place and can be attached in a snap. Once experienced, this feature cannot be done without.

Solid construction

Designing a well thought-out professional camera is no mean feat. ARCA-SWISS places paramount importance on precision and stability. Not producing heavy and cumbersome solutions has its justification.

By using design innovations, carefully selected materials and specialized metal alloys, ARCA-SWISS succeeded in reducing the weight of their cameras as much as possible without compromising stability and precision. Size ratios of each component are optimized for function and relationship to the overall design.

Dampening of vibration is another area in which ARCA-SWISS M-Line and F-Line cameras excel.



Handy, future-ready accessories

ARCA-SWISS offers a wide range of well thought-out accessories for their large format cameras. Among them is a large selection of synthetic and leather bellows units in a variety of sizes and shapes. Compendium lens hoods, filter holders, filters, Polaroid backs, reduction plates, reflex mirrors, focusing aids, shutter systems, digital backs or adapters for them are all part of the assortment. ARCA-SWISS set new standards in professional cameras with the introduction of three devices that make a photographer's job easier: the patented SIM light metering system, the Microlink electronic shutter system and the eidos multi-function module: intelligence you can rely on.

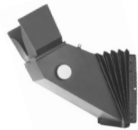

Viewing aids

Viewing aids are tools which assist in controlling the image. ARCA-SWISS's unique patented binocular reflex viewers for the medium format and 4x5" cameras produce a righted, magnified groundglass image. Unparalleled brightness is achieved even when the camera is shifted, thanks to a patented shift module. The soft padding around the viewing hood on all viewers ensures

no stray light will interfere with the image - even eyeglass wearers have no problems. The viewing hood, combined with the adjustable bellows made of soft leather or the self-supporting bellows are alternatives for devotees of groundglass viewing. The binocular magnifier can be used or not, as desired.

Use of a single lupe is also an option. The focusing bellows can be used on both 6x9 and 4x5 cameras. It is very compact when folded. The accuracy of the focus setting



also depends on the quality of the groundglass image. ARCA-SWISS's groundglass boasts an extraordinarily bright and crisp groundglass image for perfect image control.

Lens shading

The compendium is an important tool to guarantee high-contrast images free of stray light effects: it protects the lens from unwanted rays of light. There are two complimentary solutions available. The compendium with scissor-extension is the ideal option when considering size and complexity. Greater degrees of freedom can



be obtained by using a multipurpose standard and a filter holder frame in conjunction with a standard bellows unit. This setup makes difficult studio applications easier to handle.



The filter holder frame, which is attached to a rod mounted on the format frame, can be shifted and tilted. It enables the use of filters or masks in front of the lens.



Lens and shutter

ARCA-SWISS and the lens manufacturers offer a complete program of various shutters for lenses from 35mm to 1000mm. They all follow the principle of high precision and vibration minimization that can only be obtained from a mid-lens shutter.

The mechanical self-cocking shutter

Copal: stepless shutter selection.

The mechanical self-cocking shutter

Prontor Professional: no manual cocking required. The aperture can be selected in third-stop in-crements. Aperture and shutter close to the selected value when the cable release is pressed or by activating the mechanical control unit. The aperture/shutter unit can be opened equally easily after the exposure.

ARCA-SWISS Microlink

The digitally controlled ARCA-SWISS Microlink shutter, combined with the eidos multi-function module, offers the highest degree of precision and ease of operation.

Film backs

Adapters are available to mount various manufacturers backs.



Digital backs

ARCA-SWISS offers both their own digital back as well as those of other leading manufacturers.



The monorail

The backbone of any professional camera. ARCA-SWISS uses it to offer unlimited freedom with maximum stability.



The telescopic monorail

Consisting of an extension bracket and two monrail units, this is a flexible and amazingly efficient solution. The telescopic monorail is available in lengths of 30cm to 100cm. The monrail units move freely in the extension bracket and can be fastened using handy quick-locks.

This system enables lightning-quick extension adjustments, rough focusing and subject distance modifications. Close-ups and distant-subject shots can be achieved over a wide range without requiring additional accessories.

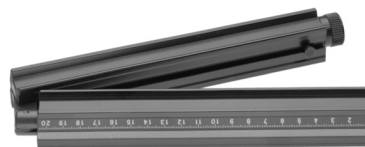

The collapsible monorail

The collapsible monorail for the ARCA-SWISS F-Line C consists of two monrail units joined by a precision folding mechanism which holds the monrail units together when folded. Only a short extension bracket is required.



Additional extensions

Should the extension have to be increased quickly, none of the basic camera settings have to be changed: the monorail extension can be inserted directly into the monorial unit.



Unlimited extension

Combining extension brackets and various lengths of monorail units allows the monorail to be adapted to any desired extension. In short, ARCA-SWISS sets no limits on creativity.

Camera mount

The camera mounting system does not figure largely in conventional designs regarding vibration dampening. But the entire photographic system has to be free of vibration to produce perfect images. The ARCA-SWISS Monoball® B is the state-of-the-art tripod head that meets any requirement of a camera system. Using the accessory ground plate makes worm's-eye photographs a reality.



Monorail units

041040	Rail unit I	0 - 40cm
041115	Rail unit II	0 - 15cm
041120	Rail unit II	0 - 20cm
041125	Rail unit II	0 - 25cm
041130	Rail unit II	0 - 30cm
041140	Rail unit II	0 - 40cm
041150	Rail unit II	0 - 50cm
041202	Rail Stopper Set II	
041225	Rail Extension II	25cm

Extension brackets

042008	Extension bracket I	85mm
042108	Extension bracket II	85mm
042130	Extension bracket II	300mm
042140	Extension bracket II	400mm
042150	Extension bracket II	500mm
042180	Extension bracket II	800mm
042199	Extension bracket II	1000mm

Optical bench telescopic

043130	Optical bench 30 cm telescopic
043140	Optical bench 40 cm telescopic
043150	Optical bench 50 cm telescopic
043180	Optical bench 80 cm telescopic
043199	Optical bench 100 cm telescopic

Optical bench collapsible

044130	Optical bench 30cm collapsible (incl. extension bracket 8.5cm)
044140	Optical bench 40cm collapsible (incl. extension bracket 8.5cm)
044150	Optical bench 50cm collapsible (incl. extension bracket 8.5cm)

Tripod heads

801001.2	ARCA-SWISS Monoball B1 with quickset device
801001.3	ARCA-SWISS Monoball B2 with quickset device
801011.2	ARCA-SWISS Monoball B1 with plate and 3/8" mount
801013.2	ARCA-SWISS Monoball B1 with plate and 1/4" mount
802000	Quickset device with 3/8" threaded socket, 84mm
802001	Quickset device with 1/4" threaded socket, 84mm
802002	Quickset device with 3/8" threaded socket, 60mm
802003	Quickset device with 1/4" threaded socket, 60mm



011000 F -classic 6x9

- 043130 Optical bench 30 cm telescopic
- 052000 Function carrier F -classic, front
- 052001 Function carrier F -classic, rear
- 061000 Format frame 6x9 F -classic, front
- 061001 Format frame 6x9 F -classic, rear
- 080003 Groundglass frame 6x9 with Fresnel (direct mount)
- 071000 Universal bellows 6x9, 20cm, leather
Weight: 2.4 kg.

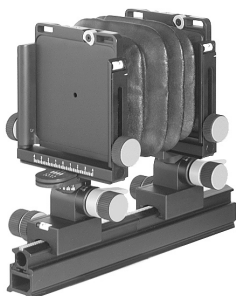
**012000 F -classic 4x5"**

- 043130 Optical bench 30 cm telescopic
- 052000 Function carrier F -classic, front
- 052001 Function carrier F -classic, rear
- 062000 Format frame 4x5" F -classic, front
- 062001 Format frame 4x5" F -classic, rear
- 080007 Film holder and groundglass frame 4x5" with Fresnel
- 072040 Standard bellows 4x5, 38cm, synthetic
Weight: 3.4 kg.

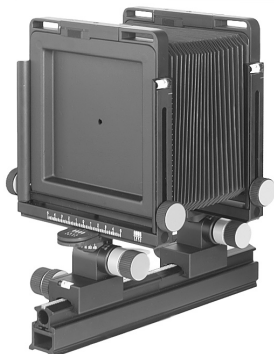
**013000 F -classic 5x7"**

- 043140 Optical bench 40 cm telescopic
- 052000 Function carrier F -classic, front
- 052001 Function carrier F -classic, rear
- 062000 Format frame 4x5" F -classic, front
- 062021 Format frame 5x7" F -classic, rear
- 088012 Film holder and groundglass frame 5x7" with Fresnel
- 075000 Standard bellows 5x7", 50cm, biconical, synthetic
Weight: 3.8 kg.

**014000 F -classic 8x10"**

- 043150 Optical bench 50 cm telescopic
- 052000 Function carrier F -classic, front
- 052001 Function carrier F -classic, rear
- 062000 Format frame 4x5" F -classic, front
- 062031 Format frame 8x10" F -classic, rear
- 088013 Film holder and groundglass frame 8x10" with Fresnel
- 076000 Standard bellows 8x10", 50cm, biconical, synthetic
Weight: 4.1 kg.

**ARCA-SWISS F -classic C**

ARCA-SWISS F -classic C (compact) cameras are identical to F -classics, but have a collapsible monorail instead of the telescopic monorail.

011001 F -classic 6x9 C

- 044130 Optical bench 30cm collapsible
Weight: 2.2 kg.

012001 F -classic 4x5" C

- 044130 Optical bench 30cm collapsible
Weight: 3.2 kg.

013001 F -classic 5x7" C

- 044140 Optical bench 40cm collapsible
Weight: 3.6 kg.

014001 F -classic 8x10" C

- 044150 Optical bench 50cm collapsible
Weight: 3.9 kg.



014002 F -metric 8x10"

- 043150 Optical bench 50 cm telescopic
- 052101 Function carrier F -metric, front
- 052102 Function carrier F -metric, rear
- 062010 Format frame 4x5" F -metric, front
- 062031 Format frame 8x10" F -classic, rear
- 088013 Film holder and groundglass frame 8x10" with Fresnel
- 076000 Standard bellows 8x10", 50cm, biconical, synthetic
Weight: 4.3 kg.

**011002 F -metric 6x9**

- 043130 Optical bench 30 cm telescopic
- 052101 Function carrier F -metric, front
- 052102 Function carrier F -metric, rear
- 061010 Format frame 6x9 F -metric, front
- 061011 Format frame 6x9 F -metric, rear
- 080003 Groundglass frame 6x9 with Fresnel (direct mount)
- 071000 Universal bellows 6x9, 20cm, leather
Weight: 2.6 kg.

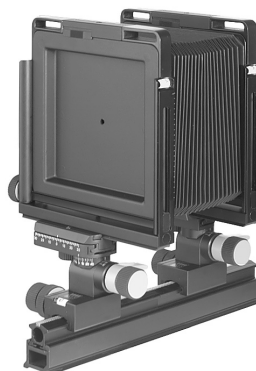
**012002 F -metric 4x5"**

- 043130 Optical bench 30 cm telescopic
- 052101 Function carrier F -metric, front
- 052102 Function carrier F -metric, rear
- 062010 Format frame 4x5" F -metric, front
- 062011 Format frame 4x5" F -metric, rear
- 080007 Film holder and Groundglass frame 4x5" with Fresnel
- 072040 Standard bellows 4x5, 38cm, synthetic
Weight: 3.6 kg.

ARCA-SWISS F -metric C

Arca Swiss F -metric C (compact) cameras are identical to F -metrics, but have a collapsible monorail instead of the telescopic monorail.

- 011003 F -metric 6x9 C**
- 044130 Optical bench 30cm collapsible
Weight: 2.4 kg.
- 012003 F -metric 4x5" C**
- 044130 Optical bench 30cm collapsible
Weight: 3.4 kg.
- 013003 F -metric 5x7" C**
- 044140 Optical bench 40cm collapsible
Weight: 3.8 kg.
- 014003 F -metric 8x10" C**
- 044150 Optical bench 50cm collapsible
Weight: 4.1 kg.

**013002 F -metric 5x7"**

- 043140 Optical bench 40 cm telescopic
- 052101 Function carrier F -metric, front
- 052102 Function carrier F -metric, rear
- 062010 Format frame 4x5" F -metric, front
- 062024 Format frame 5x7" F -metric, rear
- 088012 Film holder and groundglass frame 5x7" with Fresnel
- 075000 Standard bellows 5x7", 50cm, biconical, synthetic
Weight: 4.0 kg.





018100 M -monolith 6x9

- 043130 Optical bench 30 cm telescopic
- 055000 Function carrier **M** -monolith front
- 055001 Function carrier **M** -monolith rear
- 063003 Format frame **M** -monolith 6x9 front with orbix® tilt
- 063002 Format frame **M** -monolith 6x9 rear
- 080003 Groundglass frame 6x9 with Fresnel (direct mount)
- 071001 Standard bellows 6x9, 24cm, synthetic
Weight: 4.2 kg.



018400 M -monolith 8x10"

- 043150 Optical bench 50 cm telescopic
- 055000 Function carrier **M** -monolith front
- 055001 Function carrier **M** -monolith rear
- 063023 Format frame **M** -monolith 4x5" front with orbix® tilt
- 063040 Format frame **M** -monolith 8x10" rear
- 088013 Film holder and groundglass frame 8x10" with Fresnel
- 076000 Standard bellows 8x10", 50cm, biconical, synthetic
Weight: 5.9 kg.



018200 M -monolith 4x5"

- 043140 Optical bench 40 cm telescopic
- 055000 Function carrier **M** -monolith front
- 055001 Function carrier **M** -monolith rear
- 063023 Format frame **M** -monolith 4x5" front with orbix® tilt
- 063021 Format frame **M** -monolith 4x5" rear
- 080007 Film holder and Groundglass frame 4x5" with Fresnel
- 072040 Standard bellows 4x5", 38cm, synthetic
Weight: 5.3 kg.

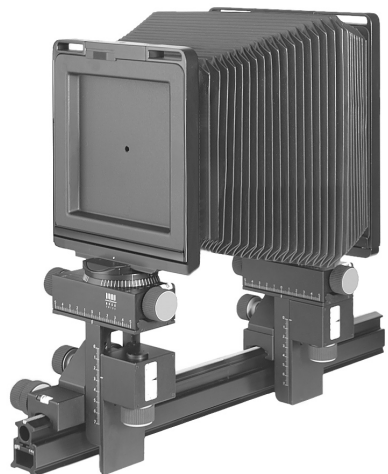

018300 M -monolith 5x7"

- 043150 Optical bench 50 cm telescopic
- 055000 Function carrier **M** -monolith front
- 055001 Function carrier **M** -monolith rear
- 063023 Format frame **M** -monolith 4x5" front with orbix® tilt
- 063030 Format frame **M** -monolith 5x7" rear
- 088012 Film holder and groundglass frame 5x7" with Fresnel
- 075000 Standard bellows 5x7", 50cm, biconical, synthetic
Weight: 6.2 kg.

kit

The economy priced Discovery allows you to extend your system with the components of the already established ARCA-SWISS camera program. The Discovery kit comes with a Fresnel lens and a camera bag. In quintessential ARCA-SWISS fashion, the standards have been designed to make adjustments in focusing superfluous after making parallel displacements. Naturally the Discovery is yaw free as all ARCA-SWISS cameras.

**0210445 Discovery 4x5"**

041130	Monorail unit 30cm
042108	Extension bracket 8.5cm
051010	Function carrier Discovery, front
051011	Function carrier Discovery, rear
062150	Format frame Discovery, front
062151	Format frame Discovery, rear
080007	Film holder and groundglass frame 4x5" with Fresnel
072040	Bellows 4x5" standard, 38 cm, synth.
140020	Softbag/rucksack Weight: 3.1 kg.

orbix®

orbix can be added to all F-Line camera models as an accessory. The orbix's movements are perpendicular to the optical axis rather than the monorail. Focus adjustments therefore occur in the selected plane and are also easier to make. The orbix produces absolutely yaw-free movements - an indispensable feature when shooting with digital cameras because of their small sensors. Another benefit is a marked increase in movement with short focal length lenses. The orbix-dynamic model gives the user the ability to perform dynamic focus adjustments. Simply make manual adjustments in the optical axis until the desired focus is attained. Unlocking or locking of the mechanism is not required. The orbix-micrometric model offers geared control.

**orbix - extension**

The product code consists of the camera code with a "o" at the end of the number.

com

The **com** accessory is compatible with all F/M cameras. Com stands for communication. The unit transmits information regarding focus to the eidos e-module. The frame carriers have an internal electronically controlled sensor.

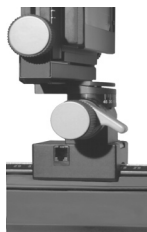
**com - extension**

The product code consists of the camera code with a "c" at the end of the number.



Wide angle

Standard

Long

071000
Universal bellows 6x9
20cm, leather



071010
Wide angle bellows 6x9
15cm, leather



071030
Wide angle bellows 6x9-4x5"
conical, 24cm, leather

072050
Wide angle bellows 4x5"
20cm, leather



072051
Wide angle bellows 4x5"
20cm, synth.



075010
Wide angle bellows 5x7"
25cm, leather



075011
Wide angle bellows 5x7"
25cm, synth.



076010
Wide angle bellows 8x10"
30cm, leather



076011
Wide angle bellows 8x10"
30cm, synth.

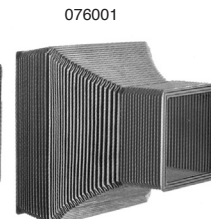

071001
Standard bellows 6x9
24cm, synth.

071025
Long bellows 6x9
50cm, synth.

071031
Standard bellows 6x9-4x5",
conical, 38cm, synth.

071032
Long bellows 6x9-4x5"
conical, 50cm, synth.

072040
Standard bellows 4x5"
38cm, synth.

072060
Long bellows 4x5"
70cm, synth.

075000
Standard bellows 5x7"
biconical, 50cm, synth.

075001
Long bellows 5x7"
biconical, 70cm, synth.

076000
Standard bellows 8x10"
biconical, 50cm, synth.

076001
Long bellows 8x10"
biconical, 70cm, synth.

011200

Format converting set F -classic 6x9

- 061000 Format frame F -classic 6x9 front
 061001 Format frame F -classic 6x9 rear
 080003 Groundglass frame 6x9, with Fresnel (direct mount)
 071000 Universal bellows 6x9, 20cm, leather

011201

Format converting set F -classic 4x5"-6x9 wide angle

- 062001 Format frame F -classic 4x5" rear
 080007 Film holder and groundglass frame 4x5", with Fresnel
 071030 Wide angle bellows 6x9-4x5" 24cm, conical, leather

011202

Format converting set F -classic 4x5"-6x9 standard

- 062001 Format frame F -classic 4x5" rear
 080007 Film holder and groundglass frame 4x5", with Fresnel
 071031 Standard bellows 6x9-4x5" 38cm, conical, synth.

012190

Format converting set F -classic 4x5"

- 062001 Format frame F -classic 4x5" rear
 080007 Film holder and groundglass frame 4x5", with Fresnel
 072040 Standard bellows 4x5", 38cm, synth.

012200

Format converting set F -classic 5x7"

- 062021 Format frame F -classic 5x7" rear
 088012 Film holder and groundglass frame 5x7", with Fresnel
 075000 Standard bellows 5x7", 50cm, biconical, synth.

012210

Format converting set F -classic 8x10"

- 062031 Format frame F -classic 8x10" rear
 088013 Film holder and groundglass frame 8x10", with Fresnel
 076000 Standard bellows 8x10", 50cm, biconical, synth.

Format converting F -classic

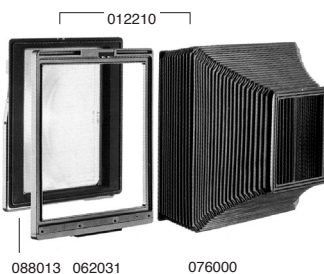
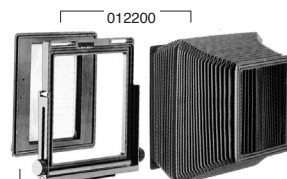
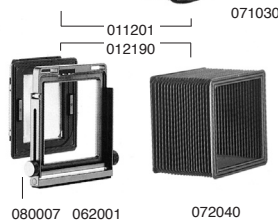
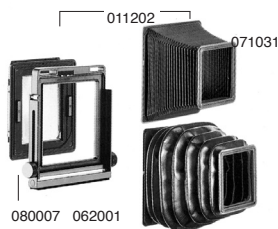
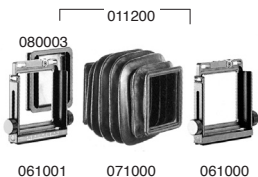

Format converting F -metric

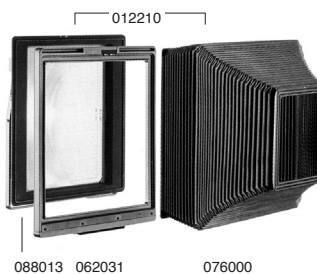
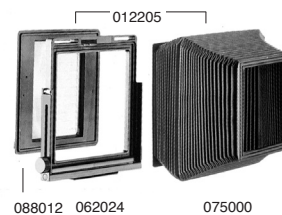
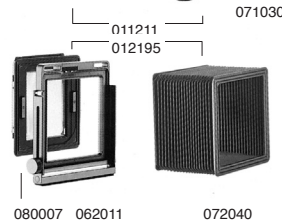
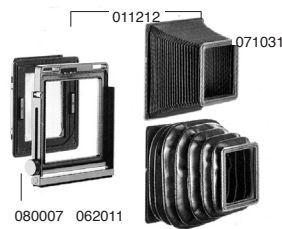
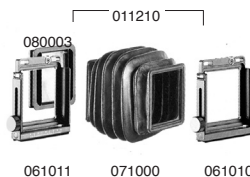
**011210**

Format converting set F -metric 6x9

- 061010 Format frame F -metric 6x9 front
 061011 Format frame F -metric 6x9 rear
 080003 Groundglass frame 6x9, with Fresnel (direct mount)
 071000 Universal bellows 6x9, 20cm, leather

011212

Format converting set F -metric 4x5"-6x9 wide angle

- 062011 Format frame F -metric 4x5" rear
 080007 Film holder and groundglass frame 4x5", with Fresnel
 071030 Wide angle bellows 6x9-4x5" 24cm, conical, leather

011211

Format converting set F -metric 4x5"-6x9 standard

- 062011 Format frame F -metric 4x5" rear
 080007 Film holder and groundglass frame 4x5", with Fresnel
 071031 Standard bellows, 6x9-4x5" 38cm, conical, synth.

012195

Format converting set F -metric 4x5"

- 062011 Format frame F -metric 4x5" rear
 080007 Film holder and groundglass frame 4x5", with Fresnel
 072040 Standard bellows 4x5", 38cm, synth.

012205

Format converting set F -metric 5x7"

- 062024 Format frame F -metric 5x7" rear
 088012 Film holder and groundglass frame 5x7", with Fresnel
 075000 Standard bellows 5x7", 50cm, biconical, synth.

012210

Format converting set F -metric 8x10" (identical to F -classic)

- 062031 Format frame F -classic 8x10" rear
 088013 Film holder and groundglass frame 8x10", with Fresnel
 076000 Standard bellows 8x10", 50cm, biconical, synth.



011809Format converting set **M** -monolith **6x9**

- 063003 Format frame **M** -monolith 6x9 front, with orbix® tilt
- 063002 Format frame **M** -monolith 6x9 rear
- 080003 Groundglass frame 6x9, with Fresnel (direct mount)
- 071001 Standard bellows 24cm, synth.

Format converting **M** -monolith**069000**

Extender for front format frame (8x10")

011810Format converting set **M** -monolith **4x5"-6x9** wide angle

- 063021 Format frame **M** -monolith 4x5" rear
- 080007 Film holder and groundglass frame 4x5", with Fresnel
- 071030 Wide angle bellows 6x9-4x5" 24cm, conical, leather

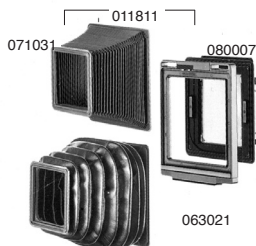
**077000**

Bellows support

011811Format converting set **M** -monolith **4x5"-6x9** standard

- 063021 Format frame **M** -monolith 4x5" rear
- 080007 Film holder and groundglass frame 4x5", with Fresnel
- 071031 Standard bellows 6x9-4x5" 38cm, conical, synth.

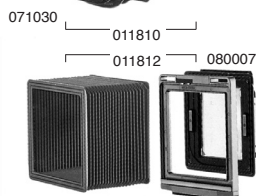
**031069**Multipurpose standard **6x9**

- 061000 Format frame
- 051010 Function carrier front

011812Format converting set **M** -monolith **4x5"**

- 063021 Format frame **M** -monolith 4x5" rear
- 080007 Film holder and groundglass frame 4x5", with Fresnel
- 072040 Standard bellows 4x5", 38cm, synth.

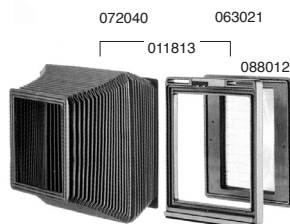
**011813**Format converting set **M** -monolith **5x7"**

- 063030 Format frame **M** -monolith 5x7" rear
- 088012 Film holder and groundglass frame 5x7", with Fresnel
- 075000 Standard bellows 5x7", 50cm, biconical, synth.

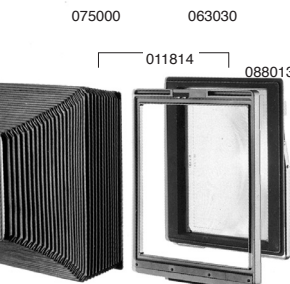
**011814**Format converting set **M** -monolith **8x10"**

- 063040 Format frame **M** -monolith 8x10" rear
- 088013 Film holder and groundglass frame 8x10", with Fresnel
- 076000 Standard bellows 8x10", 50cm, biconical, synth.

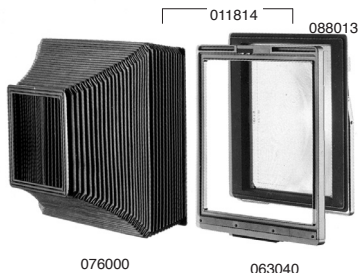
**031045**Multipurpose standard **4x5"**

- 062150 Format frame
- 051010 Function carrier front



051000

Function carrier **F** -basic front
5 functions.
Ergonomic and functionally separated controls.
Horizontal/vertical movement controls on the left.
Shift control knob on the front.
Geared focus control with separate friction/lock control on the right.
Spirit levels.

**051001**

Function carrier **F** -basic rear
5 Functions.
Ergonomic and functionally separated controls.
Horizontal/vertical movement controls on the left.
Shift control knob on the front.
Geared focus control with separate friction/lock control on the right.
Spirit levels.

052000

Function carrier **F** -classic front
5 Functions.
Ergonomic and functionally separated controls.
Horizontal/vertical movement controls on the left.
Shift control with locking tab on the front.
Geared focus control with separate friction/lock control on the right.
Spirit levels.

**052001**

Function carrier **F** -classic rear
5 Functions.
Ergonomic and functionally separated controls.
Horizontal/vertical movement controls on the left.
Shift control with locking tab on the front.
Geared focus control with separate friction/lock control on the right.
Spirit levels.

052101

Function carrier **F** -metric front
6 functions.
Ergonomic and functionally separated controls.
Horizontal/vertical movement controls on the left.
Shift is set using the self-locking geared mechanism and/or with the format frame's lock mechanism.
Geared focus control with friction/lock control on the right.
Spirit levels.

**052102**

Function carrier **F** -metric rear
6 Functions.
Ergonomic and functionally separated controls.
Horizontal/vertical movement controls on the left.
Shift is set using the self-locking geared mechanism and/or with the format frame's lock mechanism.
Geared focus control with friction/lock control on the right.
Spirit levels.

055000

Function carrier **M** -monolith front
7 Functions.
All movements via self-locking, precision geared mechanisms.
Ergonomic and functionally separated controls.
Horizontal/vertical movement controls on the left.
Shift, height and focus controls are on the right.
Additional shifting is possible using the format frame lock mechanism.
Tilt degree display.
Spirit levels.

**055001**

Function carrier **M** -monolith rear
7 Functions.
All movements via self-locking, precision geared mechanisms.
Ergonomic and functionally separated controls.
Horizontal/vertical movement controls on the left.
Shift, height and focus controls are on the right.
Additional shifting is possible using the format frame lock mechanism.
Tilt degree display.
Spirit levels.

161001

Viewing bellows, leather
6x9/4x5"

161002

Viewing bellows, self supporting
6x9/4x5"

161003

Binocular reflex viewer 6x9

161004

Binocular reflex viewer 4x5"

161012

Binocular lens board for
viewing bellows, # 161001

161013

Eye mask for #161001,
161003 and 161004

161015

Adapter frame 4x5"
for 161001

091000.2

Lens board, 110x110
flat, size "0"

091000.3

Lens board, 110x110
flat, size "1"

091000.4

Lens board, 110x110
flat, size "3"

091001.2

Lens board, 110x110
15mm recessed, size "0"

091004.2

Lens board, 110x110
7mm recessed, size "0"

091004.3

Lens board, 110x110
7mm recessed, size "1"

091041.2

Lens board, 171x171
13mm recessed, size "0"

091041.3

Lens board, 171x171
13mm recessed, size "1"

091041.4

Lens board, 171x171
13mm recessed, size "3"

091042.2

Lens board, 171x171
26mm recessed, size "0"

111000

Compendium lens hood 6x9
with scissors movement and filter
holder adapter, incl. 111007

111001

Compendium lens hood 4x5"
with scissors movement and filter
holder adapter, incl. 111008

111009

Filter/bellowholder 4x5", incl. 111008

111010

Filter/bellowholder 6x9, incl. 111007

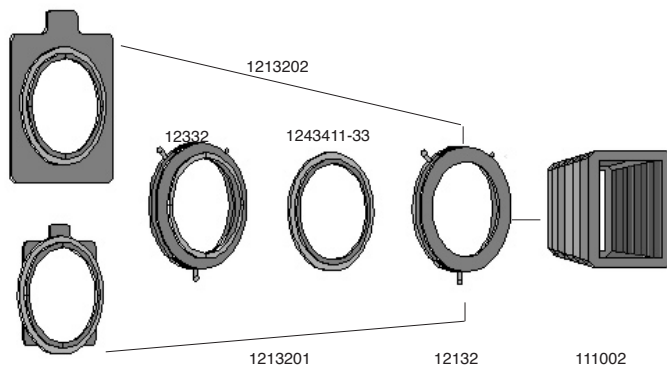
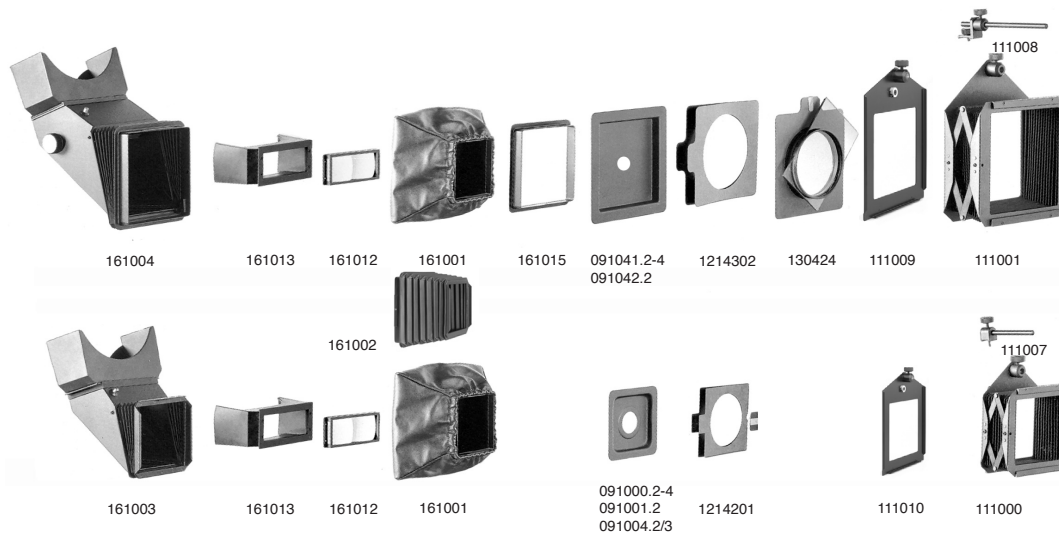
**FilterSet**

130424	Graduation filter 100x150mm
131122	Contrast filter set (6 filter) 100x100mm
131222	Conversion filter set (6 filter) 100x100mm
132322	Conversion filter set (12 filter) 100x100mm
133322	Conversion filter set (24 filter) 100x100mm

Adapter, Filter holder universal

1243411	Ø 49mm
1243412	Ø 52 mm
1243413	Ø 55 mm
1243414	Ø 58mm
1243415	Ø 60mm
1243416	Ø 62mm
1243417	Ø 67mm
1243418	Ø 77mm
1243419	Ø 82mm
1243420	Ø 95mm
1243422	Ø 105mm
1243431	Hasselblad 50
1243432	Hasselblad 60
1243433	Hasselblad 70

Filter Holders

12132	Filter holder universal 100x100mm
12332	Filter holder extension universal (2 filter)
1211502	Filter holder with thread 105 mm for compendium 4x5"
1213201	Filter holder, 100x100mm revolves for compendium 6x9
1213202	Filter holder 100x100mm revolves for compendium 4x5"
1214201	Filter holder carton 100x100mm compendium 6x9
1214302	Filter holder carton 125x125mm compendium 4x5"
111002	Compendium for Filter holder universal





200006
 Lens board adapter
 ARCA-SWISS 110x110/
 ARCA-SWISS 171x171



200009
 Rollfilm holder adapter Hasselblad
 without transport.

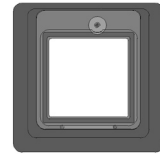

200002
 Format reduction board
 ARCA-SWISS 4x5"- 6x9
 without groundglass holder.
 Equal film-plane.



200007
 Lens board adapter
 ARCA-SWISS 110x110 - Sinar



200011
 Rollfilm holder adapter Mamiya RZ
 without transport.



200001
 Format reduction board
 ARCA-SWISS 5x7"- 4x5"
 without groundglass holder.
 Equal film-plane.



200005
 Lens board adapter
 Linhof - ARCA-SWISS 171x171



080002
 Rollfilm holder adapter
 ARCA-SWISS, Horseman,
 Mamiya RB

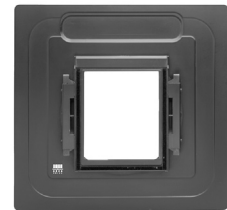

200004
 Format reduction board
 ARCA-SWISS 8x10"- 4x5"
 without groundglass holder .
 Equal film-plane.



200008
 Lens board adapter
 Sinar - ARCA-SWISS 171x171



The Microlink shutter

This electronic, mid-lens shutter is designed for precise exposure times and superb reliability. The unit is controlled via the eidos camera computer.



Eidos

Artificial intelligence for any ARCA-SWISS professional camera. The well-designed unit measures and controls the exposure, controls the shutter and calculates the required camera settings.



SIM

The ARCA-SWISS groundglass SIM (Screen Integrated Metering) allows point, integral and contrast measuring on the film plane with high exposure accuracy of day-, flash or mixed light.

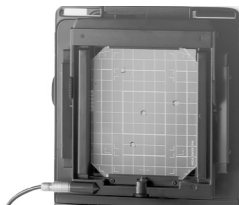

Eidos module mount

To mount the camera computer onto the monorail. Mounting plate with magnetic coating. Can be rotated through 360° with click-stops in 15° increments for optimal positioning.



Parts list e modules

90102	ARCA-SWISS eidos with camera setting, shutter control and exposure metering software
90241	Eidos module mount to attach onto the extension bracket.
90245	AC adapter and charger for eidos.
90246	Rechargeable battery for eidos
90248	Cable for ARCA-SWISS com cameras
90250	Cable for ARCA-SWISS 6x9 SIM groundglass holders
90251	Cable for ARCA-SWISS 4x5/8x10" SIM groundglass holders
90260	Cable for ARCA-SWISS Microlink shutters, 1.5m
90261	Cable for ARCA-SWISS Microlink shutters, 1.5m
90400	SIM groundglass holder 6x9 complete with fresnel lens
90420	SIM groundglass holder 4x5" complete with fresnel lens
90440	SIM groundglass holder 5x7" complete with fresnel lens
90460	SIM groundglass holder 8x10" complete with fresnel lens
90600	ARCA-SWISS Microlink 0 shutter
90620	ARCA-SWISS Microlink 1 shutter
90640	ARCA-SWISS Microlink 3 shutter



Explorer

Discovering the direct route from one point to another without de-tours was, and is ARCA-SWISS's goal. And a goal successfully reached time and again.

ARCA-SWISS is always at the forefront of technology, both with the electronic camera and the first professional digital imaging system.

Applications

Applications are never limited thanks to the modular camera system. Wide-angle applications with the M-monolith are limitless. Even the shortest focal lengths can be used with the flat lens board. Any high-performance digital back - be it chip or scanner - can be used. Only the application and budget dictate the type of back to use. Should you select the medium format ARCA SWISS because of the small sensors, the camera can be expanded for use with 4x5 scanners or even 8x10 film at any time.

Quality

Quality of an ARCA-SWISS camera is of the highest standards thanks to its perfect design and precise construction. The self-locking geared mechanisms of the F-metric and M-monolith cameras make controlling the camera a simple and exact task. Equipped with the orbix® translation unit, movements are more precise than with other systems which, in turn, leads to better pictures.

Flexibility

Flexibility is a by-product of the interchangeable monorail system as well as lightweight design. An ARCA-SWISS F-Line camera with a scanning back on a short rail and small mounting block, combined with a copy stand and lightbox, becomes a flexible film scanning unit. A wide selection of adapters or rotating plates make the use of various digital backs efficient and flexible. (Adapters listed on page 15)



960000

Rotating plate unit for rectangular sensors. Interchangeable viewfinder system with rotating groundglass.



955002

The ARCA-SWISS TrueCam® Computer Interface. Adapter for ARCA-SWISS medium format cameras. ARCA-SWISS CAPT® software.



200010

Leaf adapter plate.

ARCA-SWISS M-monolith camera with a scanning back and the Microlink shutter-combined with the eidos camera computer.



ARCA-SWISS M-monolith with chip-back and rotating, sliding back



Sheet holders

- 602002 Film holder 4x5"
 603002 Film holder 5x7"
 604002 Film holder 8x10"

**Rollfilm holders**

- 611000 Rollfilm holder 6x7 /120
for 6x9 cameras
 611002 Rollfilm holder 6x7 /120
for International back 4x5"
 611010 Rollfilm holder 6x9 /120
for 6x9 cameras
 611012 Rollfilm holder 6x9 /120
for International back 4x5"
 611014 Rollfilm holder 6x7 /120
for 6x9 cameras
incl. adapter 080002
 611016 Rollfilm holder 6x9 /120
for 6x9 cameras
incl. adapter 080002
 611022 Rollfilm holder 6x12 /120
for International back 4x5"

**Polaroid backs**

- 621001 Polaroid back for ARCA-SWISS
medium-format cameras 6x9
Pack -film 8.3 x 10.8cm
 623000 Polaroid back 405, special
version for all ARCA -SWISS 4x5"
cameras. Pack film 8.3 x 10.8cm
 622000 Polaroid back 545i
for Polaroid sheet film.



621001 623000 622000

Groundglasses

- 170011 Groundglass for 6x9
 170014 Groundglass for 4x5"
 170017 Groundglass for 5x7"
 170018 Groundglass for 8x10"
 170030 Groundglass protector 4x5"

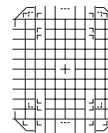
**Fresnel lenses**

- 180022 Fresnel lens for 6x9
 180024 Fresnel lens for 4x5"
 180025 Fresnel lens for 5x7"
 180026 Fresnel lens for 8x10"

Mirrors

- 210001 Mirror for angle photography
in metal casing.
 210002 Mirror for angle photography
in metal casing. 50% reflecting.

**Cases**

- 140004 6x9 F-Line case "eco 69"
Weight: 3.7 kg.
 140005 4x5" F/M-Line, case "eco 45"
Weight: 5.1 kg.
 140006 F-Line 4x5"/M-Line 6x9 case "duo"
Weight: 4.3 kg.
 140012 Leather case for F-Line C 6x9,
leather, light grey
Weight: 1.4 kg.
 140013 Leather case for F-Line C 6x9
leather, light brown
Weight: 1.4 kg.
 140020 Softbag/rucksack for F-Line cameras
(monorail up to 30cm)
Weight: 2.4 kg.



140020



140012/140013



140005



140004



140006



Example of benches extension

optical benches	to 50 cm	to 60 cm	to 70 cm	to 80 cm	to 100 cm +
30 cm collapsible	with rail extension 25cm		with extension bracket 40cm and rail unit 20cm	with extension bracket 40cm and rail unit 30cm	with extension bracket 50cm and rail unit 50cm
30 cm telescopic (45 cm extended)		with rail unit 30cm	with rail unit 40cm	with rail unit 50cm	with rail unit 40cm and rail unit 50cm
40 cm collapsible		with rail extension 25cm	with extension bracket 30cm and rail unit 20cm	with extension bracket 30cm and rail unit 30cm	with extension bracket 40cm and rail unit 40cm
40 cm telescopic (60cm extended)			with rail unit 30cm	with rail unit 40cm	with two rail unit 40cm
50 cm collapsible			with rail extension 25cm	with extension bracket 30cm and rail unit 30cm	with extension bracket 40cm and rail unit 40cm
50 cm telescopic (75 cm extended)				with rail unit 40cm	with rail unit 50cm

Extensions and bellows

bellows extension	format	focus	bellows	material	article
15 cm 20 cm 25 cm 50 cm	6x9	35-75 mm 55-150 mm 150-210 mm 210-480 mm	wide angle universal standard long	leather leather synthetic synthetic	071010 071000 071001 071025
24 cm 38 cm 50 cm	6x9 - 4x5"	35-210 mm 150-300 mm 210-480 mm	wide angle standard long	leather, conical synthetic, conical synthetic, conical	071030 071031 071032
20 cm 20 cm 38 cm 70 cm	4x5"	35-210 mm 35-180 mm 150-240 mm 240-600 mm	wide angle wide angle standard long	leather synthetic synthetic synthetic	072050 072051 072040 072060
25 cm 25 cm 50 cm 70 cm	5x7"	72-210 mm 72-210 mm 210-360 mm 300-600 mm	wide angle wide angle standard long	leather, biconical synthetic synthetic, biconical synthetic, biconical	076010 075011 075000 075001
30 cm 30 cm 50 cm 70 cm	8x10"	115-240 mm 115-240 mm 155-360 mm 300-600 mm	wide angle wide angle standard long	leather, biconical synthetic synthetic, biconical synthetic, biconical	076010 076011 076000 076001

Lens boards for wide angle lenses

model	lens boards	rodenstock apo grandagon 4.5/35mm	rodenstock apo grandagon 4.5/45mm	rodenstock apo grandagon 4.5/55mm	schneider super angulon XL 5.6/47mm
F -classic 6x9 F -classic 4x5"	110x110 mm 171x171 mm	15 mm recessed 25 mm recessed	standard standard	standard standard	7 mm recessed standard
F -metric 6x9 F -metric 4x5"	110x110 mm 171x171 mm	15 mm recessed 25 mm recessed	standard standard	standard standard	7 mm recessed standard
M -monolith 6x9 M -monolith 4x5"	110x110 mm 171x171 mm	standard 25 mm recessed	standard standard	standard standard	standard standard



